

TGS 5042 - for the detection of Carbon Monoxide

Features:

- * Battery operable
- * High repeatability/selectivity to CO
- * Linear relationship between CO gas concentration and sensor output
- * Simple calibration
- * Long life
- * UL recognized component
- * Meets UL2034, EN50291, and RoHS requirements

Applications:

- * Residential and commercial CO detectors
- * CO monitors for industrial applications
- * Ventilation control for indoor parking garages
- * Recreational vehicle CO detectors
- * Marine CO detectors
- * Fire detection

Figaro's **TGS5042** is a battery operable electrochemical sensor which offer several advantages over traditional electrochemical sensors. Its electrolyte is environmentally friendly, it poses no risk of electrolyte leakage, can detect concentrations as high as 1% CO, operates in a range from -40° and +70°C, and it has lower sensitivity to interferant gases. With a long life, good long term stability, and high accuracy, this sensor is the ideal choice for CO detectors with digital display. OEM customers will find individual sensors data printed on each sensor in bar code form, enabling users to skip the costly gas calibration process and allowing for individual sensor tracking. TGS5042 utilizes a standard AA battery-sized package.



The figure below represents typical sensitivity characteristics, all data having been gathered at standard test conditions (see reverse side of this sheet). The Y-axis shows the output current of the sensor ($I_{out}/\mu A$) in each gas. Output current is linear to CO concentration, with a deviation of less than $\pm 5\%$ in the range of 0~500ppm.

Sensitivity Characteristics:

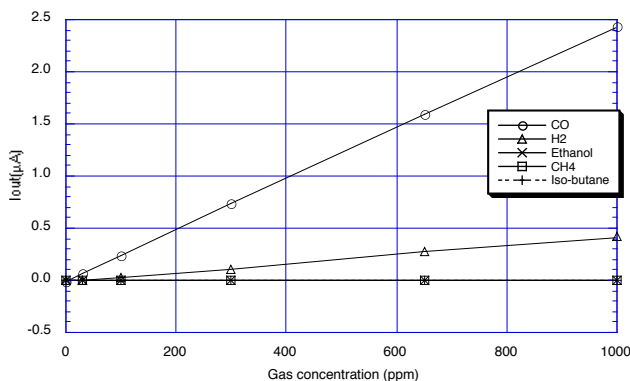

The figure below represents typical temperature dependency characteristics. The Y-axis shows the sensor output ratio (I/I_0) as defined below. The linear relationship between I/I_0 and CO concentration is constant regardless of the CO concentration range.

I = Sensor output current in 400ppm of CO at various temperatures

I_0 = Sensor output current in 400ppm at 20°C/50%RH

Temperature Dependency:

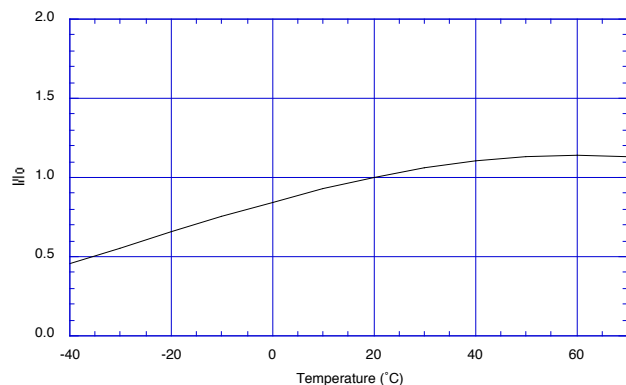

IMPORTANT NOTE: OPERATING CONDITIONS IN WHICH FIGARO SENSORS ARE USED WILL VARY WITH EACH CUSTOMER'S SPECIFIC APPLICATIONS. FIGARO STRONGLY RECOMMENDS CONSULTING OUR TECHNICAL STAFF BEFORE DEPLOYING FIGARO SENSORS IN YOUR APPLICATION AND, IN PARTICULAR, WHEN CUSTOMER'S TARGET GASES ARE NOT LISTED HEREIN. FIGARO CANNOT ASSUME ANY RESPONSIBILITY FOR ANY USE OF ITS SENSORS IN A PRODUCT OR APPLICATION FOR WHICH SENSOR HAS NOT BEEN SPECIFICALLY TESTED BY FIGARO.

Basic Measuring Circuit:

The diagram at the right shows the basic measuring circuit of TGS5042. The sensor generates a minute electric current which is converted into sensor output voltage (Vout) by an op-amp/resistor (R2) combination. An additional resistor (R1) is required to prevent polarization of the sensor when circuit voltage is off.

Figaro recommends the following electrical parts:

- R1 : 1kΩ
- R2 : 100kΩ
- C1 : 22μF
- IC : AD708

NOTE: When voltage is applied to the sensor output terminal, the sensor may be damaged. Voltage applied to the sensor should be strictly limited to less than ±10mV.

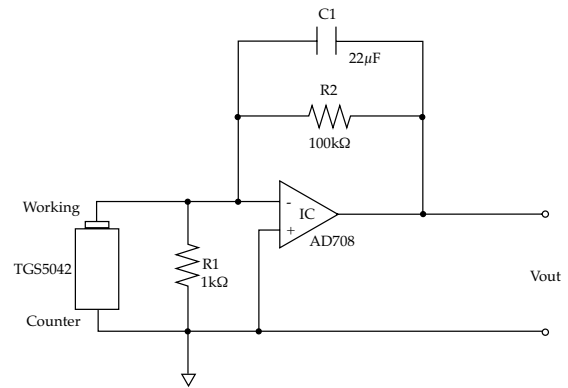

Basic measuring circuit of TGS5042

Specifications:

Item	Specification
Model number	TGS 5042
Target gases	Carbon monoxide
Typical detection range	0 ~ 10,000 ppm
Output current in CO	1.00~3.75nA/ppm
Baseline offset	<±15ppm equivalent
Operating temperature	-10°C ~ +60°C (continuous) -40°C ~ +70°C (intermittent)
Operating humidity	5 ~ 99%RH (no condensation)
Response time (T90)	within 60 seconds
Expected accuracy (*)	±20% at 0-100ppm of CO ±15% at 100-500ppm of CO (at 20±5°C/50±20%RH)
Storage conditions	-10°C ~ +60°C (continuous) -40°C ~ +70°C (intermittent)
Weight	approx. 12g
Standard test conditions	20±2°C, 40±10%RH

(*) assumes calibration points of 0 and 500ppm of CO, exposure time of 4 minutes, one day of aging in detector.

Structure and Dimensions:

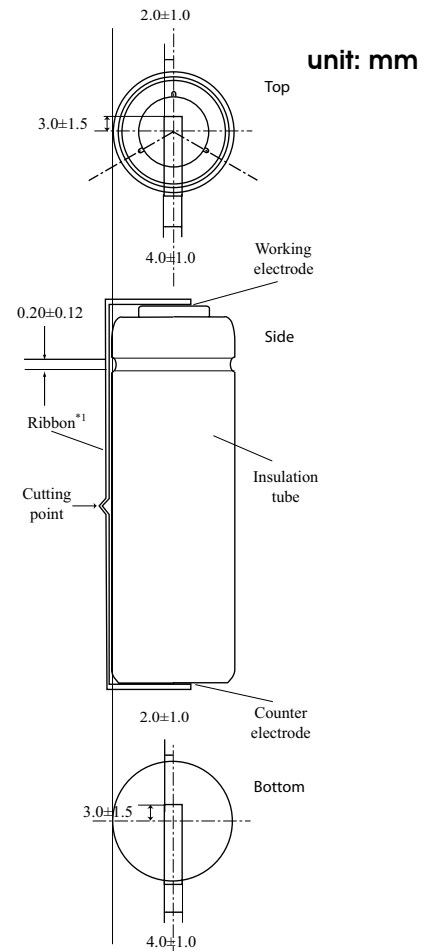

NOTE 1: When the sensor is shipped, the working electrode and counter electrode are connected (i.e. short circuited) by the metal ribbon in order to avoid polarization of the electrodes. To measure the sensor output, the ribbon should be cut and the sensor connected to a measuring circuit (see example above). The cutting point as indicated can be used to cut the ribbon easily.

FIGARO ENGINEERING INC.
1-5-11 Senba-nishi
Mino, Osaka 562-8505 JAPAN
Tel: 81-72-728-2567
Fax: 81-72-728-0467
email: figaro@figaro.co.jp
www.figaro.co.jp